

Aquablend 1000 Thermostatic Mixing Valve

ATM710

Aquablend's technology provides superior control, under changing pressure and temperature conditions as well as at ambient start up when scald protection is needed most. The proven performance, reliability and low 'whole of life' cost makes Aquablend a popular choice with specifiers, engineers, plumbers and property owners.

FEATURES

- Standards Licensed to AS4032.1 - Thermostatic Mixing Valves
- Scald and thermal shock protection with rapid thermal shut-off if either the cold or hot water supply fail
- Highly responsive temperature control, maintaining outlet temperature within +/- 2°C under changing inlet temperature and pressure conditions
- Delivers excellent flow, operating at a minimum pressure of 20kPa
- Can be upside down or sideways, inlet and outlet connections may be rotated to suit pipework design



OPTIONS

In lockable SS cabinet with recess lid **ATMS710R-350**
Smart Flow® TMV Monitoring & Control System

For more options contact your Enware representative



Product Codes

ATM710 15mm MI Inlet 20mm MI Outlet with
15mm MI Adaptor

Technical Information

Mixed Temperature Range	38° to 50°C
Dynamic Inlet Pressures	Min 20kPa Max 500kPa For optimum operation it is recommended that the hot and cold water supply pressures be balanced within +/- 10%
Static Inlet Pressures	Maximum 1600kPa for testing purposes/system commissioning
Inlet size	½" Compression Nuts
Outlet size	1" with 1"x ½" and 1" x ¾" BSP adaptors
Inlet Temperatures	Cold Supply: Min-5°C Max-30°C Hot Supply: Min-55°C Max-90°C Hot to Mix temperature differential required for stable operation is Minimum: 10°C
Inlet Pressure Ratio	H - PL = H ₁ C - PL = C ₁ H ₁ : C ₁ = Max 10:1 C ₁ : H ₁ = Max 10:1 H = Hot inlet pressure C = Cold inlet pressure PL = Pressure Loss
Flow Rates	39 lpm@300kPa pressure loss
Minimum Flow Rate for stable outlet temperature	4 lpm recommended for optimum performance

Enware tap ware must be installed in accordance with the provisions of AS/NZS 3500. Installations not complying with AS/NZS 3500 may void the product and performance warranty provisions.

HEADLOSS CHARACTERISTICS OF AQUABLEND 1000

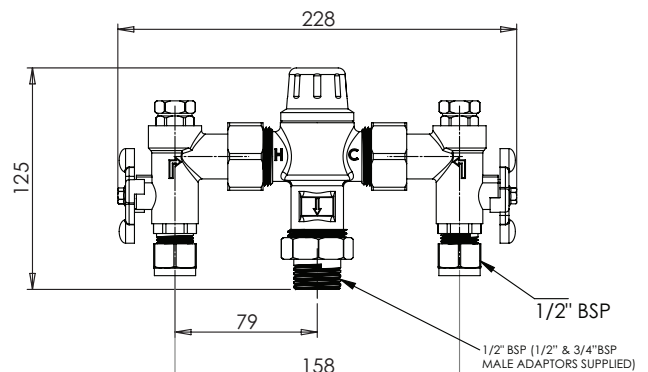
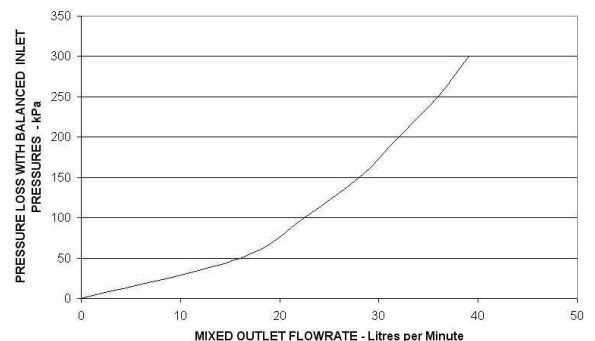

Version: Jun 20

Call 1300 369 273
www.enware.com.au

Enware Australia Pty Limited
9 Endeavour Rd Caringbah NSW 2229 Australia
Ph: 02 8536 4000 info@enware.com.au

